

**Specification Sheet**

**H.OIL Oil/Water Interface Meter**

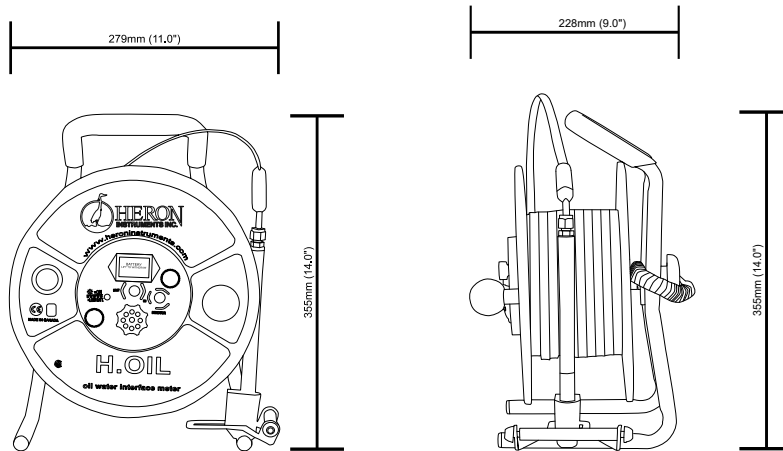

Specification		
<b>General</b>	Certification(s)	<ul style="list-style-type: none"> <li>- ASME B89.1.7-2009 &amp; MIL-STD-45662A Certified, FED GGG-T-106F &amp; EEC Class II Compliant</li> <li>- CE Certified</li> <li>- Intrinsically safe to CSA and ANSI/UL standards, class 9098-1 or 9098-81 (USA) for hazardous locations and Class I groups A,B,C and D</li> </ul>
<b>Unit</b>	Plate Size/ Material	267mm (10.5") Nylon
<b>Tape</b>	Construction	High tensile steel
	Coating	Kynar™
	Units of Measurement	Metric (mm) Imperial (1/100ft)
	Break Strength	127kg (280lbs)
	Tape Width	952mm (3/8")
<b>Probe</b>	Wetted Materials	<ul style="list-style-type: none"> <li>- 316 Grade Stainless Steel</li> <li>- Viton</li> <li>- Delrin</li> <li>- ABS &amp; Grilamid</li> </ul>
	Length	200mm (7.9")
	Diameter	19mm (.74")
	Removable?	Yes
	Depth Rating	IP68
<b>Electronic Panel</b>	Operating Mode(s)	<ul style="list-style-type: none"> <li>- Static</li> <li>- Product Interface</li> </ul>
	Power Source	9V Alkaline Battery
	Detects	<ul style="list-style-type: none"> <li>- LNAPL</li> <li>- DNAPL</li> </ul>
	Audio/Visual Indication	<ul style="list-style-type: none"> <li>- LED</li> <li>- 80dbi Buzzer</li> </ul>
	Max Operating Temperature	80° C (176°F)
<b>Included</b>	Carry Case (material)	600D PVC Polyester
<b>Warranty</b>	Unit (Probe)	5 Years (Probe 1 year)